



Level 3 DC Charging Station

DC180

180kW
250 Amps
ISO 15118



Features

- ✓ **Scalable:** PowerPump's DC fast charging stations feature a modular design with a scalable capability, enabling straightforward configuration of charging capacities ranging from 60kW to 180kW. This design caters to the specific requirements of the charging site, ensuring scalability to meet both current and future needs without the need to replace the entire cabinet.
- ✓ **Charging Outlet:** Dual Connector CCS1, or CCS1 + NACS, or CCS1 + CHAdeMO connector with retractable cable management that can charge any vehicle on the road.
- ✓ **Safe and Reliable:** DC180 stations are meeting the stringent requirements of the nation's leading safety standards organization.
- ✓ **Hardware:** DC180 stations are rugged waterproof IP54 rated they can be installed outdoors or indoors, built to withstand the elements.
- ✓ **OCPP Networked Charging:** Receive automatic software updates that deliver the latest improvements and features. Remotely monitor, manage multiple charging sites in one place and configure stations. You can also get real-time station information, track the charging status of all vehicles.

AC Nominal Input

Phase/Lines	3 phase + neutral + PE
Voltage	480V
Max . input current	230A
Frequency	50Hz / 60Hz (±10%)

DC Nominal Output

Voltage	150-1000V DC
Constant power	180KW

Electrical Parameter

Power Factor	≥0.99
Unequal Current Ratio	≤ 5%
Stable voltage accuracy	≤±0.5%
Stable Current Accuracy	≤±1%
Efficiency	≥ 95% (50%-100% load)

User Interface

Charging Outlet	Dual Connector CCS1, or CCS1 + NACS, or CCS1 + CHAdeMO
Cable Length	16.4 Feet (standard)
LED Indicator	Diode Strip Light
LCD screen	10-inch Daylight readable touchscreen
Emergency Stop Button	Yes
Startup Mode	Plug-and-play/RFID card
RFID	Yes

Communication

Connectivity	4G, Wi-Fi, Ethernet
Communication Protocol	OCPP 1.6 (JSON)

Environmental Index

Operation Temperature	-40°C ~ 50°C
Working Humidity	5%-95% without condensation
Working Altitude	<2000m
Protection Grade	IP54
Application Site	Indoor/Outdoor
Cooling Method	Fan cooling

Protection

Multiple Protection	Over/Under voltage protection, overload protection, short circuit protection, over/under temperature protection, Surge protection, Communication failure
Dimension (HxWxD)	63 x 36 x 23 inch
Safety and Compliance	UL and cUL listed

⚡ Scalable
60kW 120kW 150kW 180kW

⚡ Single- unit architecture
for simplified installation

⚡ CCS1, NACS and CHAdeMo
Connector Options

⚡ Serviceable by Design
Front and Side Door
Access

Maintenance can be managed by
single person

⚡ Retractable 17ft
Charging Cable

⚡ 10 inch Daylight
Readable Touchscreen
Diode Strip Lights

⚡ Plug and Play / RFID Card

⚡ Simultaneous
Charging

Charges 2 vehicles simultaneously

⚡ Emergency Stop Button

⚡ Ethernet, Wi-Fi and 4G

ADA Compliant

63"H x 36"W x 23"D





DC60kW/120kW/150kW/180kW Pre Installation Guide

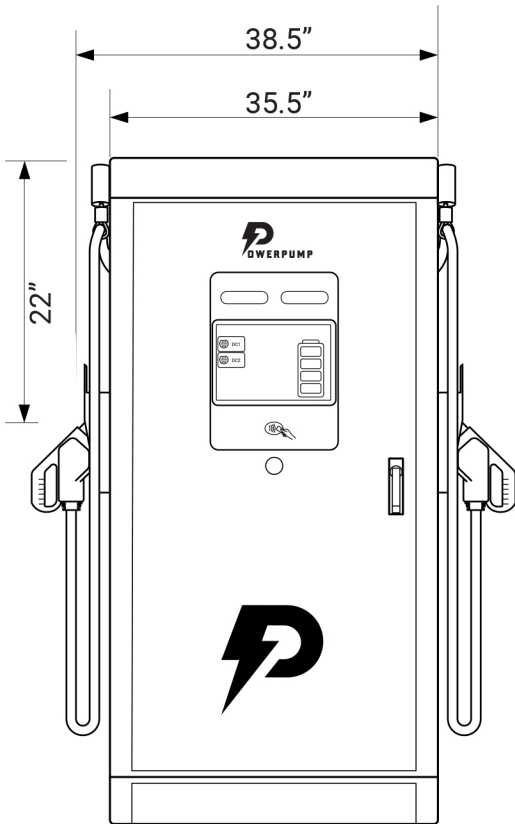

Front View

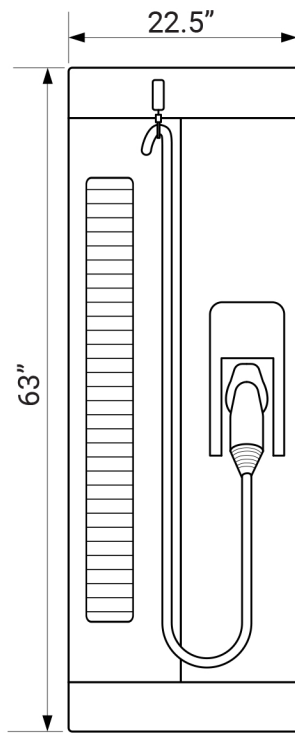

Side View

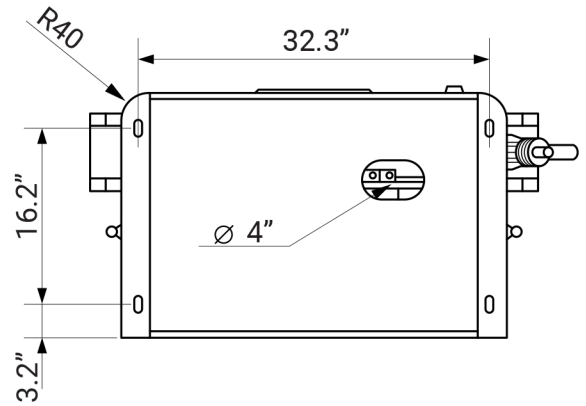

Bottom View